

# RAYSTECH

## USER MANUAL

RT 5427 HV

Version: 1.2

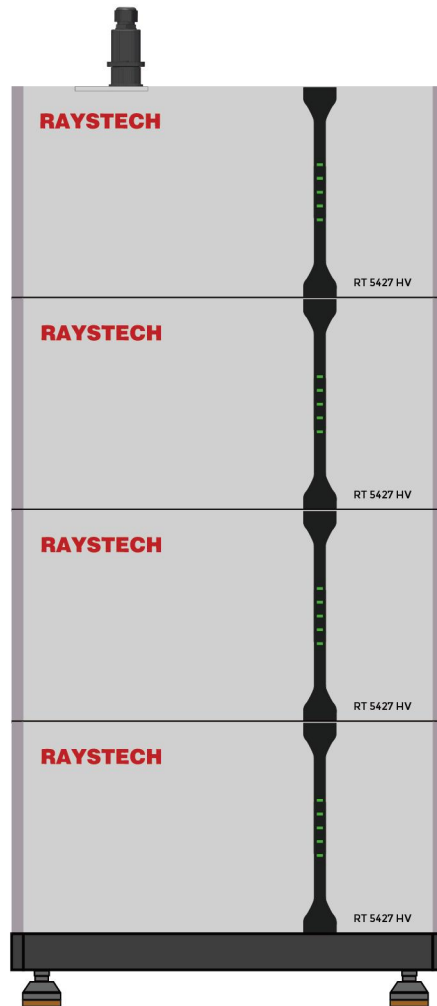

RAYSTECH (TIANJIN) PV ENERGY CO., LTD.

## About this manual

This manual is intended for the RT 5427 HV Energy Storage battery. These batteries can only be installed in Series, pay more attention to the power cable and communication cable connection.

## Statement

Compliant to Best Practice Guide for Battery Storage Equipment—Electrical Safety. Requirements- version 1- Pre-assembled integrated battery energy storage system equipment – Method 1 mandatory requirements and Optional requirements – a), c), e), f), g), h), i), j), k), l), m), n), o), p), q).

## Declaration

Raystech declares that the RT 5427 HV is in compliance with the essential requirements and other relevant of RE Directive 2014/53/EU.

Importer name: XXX (Located in EU)

Importer address: XXX (Located in EU)

---

**CONTENT**

1. Safety Introduction .....	4
1.1 Important Safety Instructions .....	4
1.2 Warnings in this Document .....	4
1.3 Battery Handling Guide .....	5
1.4 Response to Emergency Situations .....	5
1.4.1 Leaking Batteries .....	5
1.4.2 Fire .....	5
1.4.3 Wet battery .....	6
1.4.4 Damaged Battery .....	6
1.5 Installers .....	6
1.6 Scrap Battery .....	7
1.7 Contact Information .....	7
2.Guidance for Disconnection of Batteries During Shipment .....	7
3.Product Introduction .....	8
3.1 Technical Specifications .....	8
3.2 Indicators and Ports .....	9
3.2.1 Indicators .....	9
3.2.2 Power and Communication Ports .....	9
3.3 Solution of Raystech .....	11
3.4 Feature .....	12
4. Installation Prerequisites .....	12
4.1 Installation Process .....	12
4.2 Installation Position .....	13
4.3 Tools .....	13
4.4 Safety Instruments .....	14
4.5 Storage .....	14
5. Battery Installation .....	15
5.1 Checks Before Installation .....	15
5.2 Battery Installation .....	15
5.3 Connection Between Batteries .....	16
6.Commissioning .....	17
6.1 Commissioning Battery .....	17
6.2 Shutting Down Battery .....	18
7.Firmware Update .....	18

## 1. Safety Introduction

### 1.1 Important Safety Instructions







This manual contains important instructions for:

**RT 5427 HV Energy Storage product and this manual must be followed when installing and using this product.**

This product is designed and tested in accordance with international safety requirements CE, but as with all electrical and electronic equipment, certain precautions must be observed when installing and operating the product. To reduce the risk of personal injury. Ensure the installation safety and operation of the product, you must read carefully and follow all instructions, cautions, and warnings in this manual.

### 1.2 Warnings in this Document

A warning describes a hazard to equipment or personnel. It calls attention to a procedure or practice which if not correctly performed, can result in damage to or destruction of part or all of the Raystech equipment and/or other equipment connected to the Raystech equipment or personal injury.

Symbol	Description
	Caution, risk of electric shock
	Heavy enough may cause severe injure
	Keep the battery away from open flame or ignition sources
	Keep the battery away from children
	Dispose of waste batteries according to local laws and regulations
	Recycling
	Read this manual before installation and operation

For safety reasons, installers are responsible for familiarizing themselves with the contents of this manual and all warnings before performing installation.

### 1.3 Battery Handling Guide

- To protect the battery and its components from damage when transporting, handle them with care.
- Do not subject it to any strong force.
- Do not insert foreign objects into any part of the battery pack.
- Do not use cleaning solvents to clean the battery.
- The battery can't be connected directly to SELV circuit.
- Use the battery pack only as directed.
- If the battery is defective, appears cracked, is broken, gets other damage, or fails to operate. Contact the Raystech **hot line +86-22-59901199** immediately.
- Do not attempt to open, disassemble, repair, tamper, or modify the battery.

**The battery is not suitable for users to use by themselves.**

### 1.4 Response to Emergency Situations

The Raystech battery is designed with multiple safety strategies to prevent hazards resulting from failures. However, Raystech cannot guarantee their absolute safety in uncertain situations.

#### 1.4.1 Leaking Batteries

If the battery pack leaks electrolyte, avoid contact with the leaking liquid or gas. Electrolyte is corrosive and contact may cause skin irritation and chemical burns. If one is exposed to the leaked substance, do these actions:

**Inhalation:** Evacuate the contaminated area, and seek medical attention immediately.

**Eyes contact:** Rinse eyes with flowing water for 15 minutes, and seek medical attention immediately.

**Skin contact:** Wash the affected area thoroughly with soap and water, and seek medical attention immediately.

**Ingestion:** Induce vomiting as soon as possible, and seek medical attention immediately.

#### 1.4.2 Fire

In case of a fire, make sure that an ABC or carbon dioxide extinguisher is

nearby and does not use water to extinguish the fire.



**WARNING**

The battery pack may catch fire when heated above 150°

If a fire breaks out where the battery is installed, do these actions:

1. Extinguish the fire before the battery catches fire.
2. If the battery has caught fire, do not try to extinguish the fire. Evacuate people immediately.

**WARNING**

If the battery catches fire, it will produce poisonous gases. Do not approach.

### 1.4.3 Wet battery

If the battery is wet or submerged in water, do not try to access it. Contact **Raystech Customer Service** or your distributor for technical assistance.

### 1.4.4 Damaged Battery

If the battery is damaged, please contact Raystech **customer service** or your distributor for help as soon as possible, because damaged batteries are dangerous and must be handled with extreme caution. Damaged batteries are not suitable for use and may cause a danger to people or property. If the battery seems to be damaged, return it to Raystech or your distributor.

**CAUTION**

Damaged batteries might export electrolyte or flammable gas, so contact Raystech for advice and information immediately. Raystech will deal with it.

## 1.5 Installers

Raystech Energy Storage battery is suggested to be installed by skilled workers or electricians.

A skilled worker is defined as a person who has been trained and qualified electrician or has all of the following skills and experience:

- Knowledge of the functional principles and operation of on-grid Energy Storage systems.
- Knowledge of the dangers and risks associated with installing and using electrical devices and acceptable mitigation methods.
- Knowledge of the installation of electrical devices
- Knowledge of and adherence to this manual, all safety precautions and best practices.

## 1.6 Scrap Battery

For scrap battery(-ies), please treat with local laws or regulations to recycle or scrap.

## 1.7 Contact Information

Use the contacts for technical assistance. The phone number is available only during business hours on weekdays.

<b>Fax</b>	+86-22-59901199
<b>Email</b>	sales@raystechgroup.com
<b>Address</b>	13TH Floor Tianqi International Mansion, Central Business District, Binhai New Area, Tianjin, China

## 2.Guidance for Disconnection of Batteries During Shipment

- RT 5427 HV is not suitable for air transport.
- Cartons that have been crushed, punctured, or torn in such a way that contents are revealed shall be set aside in an isolated area and inspected by a skilled person. If the package is deemed not to be shippable, the contents shall be promptly collected and segregated, and either the consignor or the consignee contacted.
- The DC circuit of RT 5427 HV battery has been disconnected before outgoing.
- We have conducted comprehensive tests to ensure the equipment distributed around the world is safe for shipping. These products shall be handled with care and immediately inspected if visibly damaged. If the carton is visibly damaged, please contact with **Raystech customer service** to confirm whether the battery can be used safely or not.

### 3.Product Introduction

#### 3.1 Technical Specifications

<b>Product Type</b>	RT5427 HV	RT5427 HV	RT5427 HV	RT5427 HV	RT5427 HV
<b>Total Energy*</b>	10.8kWh	16.2kWh	21.6kWh	27kWh	32.4kWh
<b>Battery Capacity</b>	53Ah				
<b>Max Recommended DOD</b>	93%				
<b>Max Dis/Charge Power</b>	12.3kW for 3S	18.4kW for 3S	24.6kW for 3S	30.8kW for 3S	36.9kW for 3S
<b>Voltage</b>	179.2~227.2V d.c	268.8~340.8V d.c	358.4~454.4V d.c	448.0~568.0V d.c	537.6~681.6V d.c
<b>Nominal Voltage</b>	204.8Vd.c	307.2Vd.c	409.6Vd.c	512.5Vd.c	614.4Vd.c
<b>Nominal Discharge Current</b>	50A				
<b>Nominal Charging Current</b>	50A				
<b>Max Charging Current</b>	60A(3s)				
<b>Max Discharging Current</b>	60A(3s)				
<b>Max Charge Voltage</b>	224Vd.c	336Vd.c	448Vd.c	560Vd.c	672Vd.c
<b>Weight(N.W.)</b>	111kg	164kg	217kg	270kg	323kg
<b>Dimension(L*W*H)</b>	660*300*700 mm	660*300*1000 mm	660*300*1300 mm	660*300*1600 mm	660*300*1900 mm
<b>Operating Condition</b>	Indoor & Outdoor (with shelter)				
<b>Operating Temperature(c ell)</b>	<b>Charge</b>	From 0~50℃			
	<b>Discharge</b>	From -20~55℃			
<b>WIFI Frequency Range</b>	2400MHz~2483MHz				
<b>Bluetooth Max. transmission Power</b>	17.8dBm				
<b>Humidity</b>	<60%(No condensed water)				
<b>Over Voltage Category</b>	II				
<b>Cooling Type</b>	Natural cooling				
<b>Installation</b>	Ground Installation				
<b>IP Rating</b>	IP65				
<b>Protective Class</b>	I				
<b>Max Connection Number</b>	6S				
<b>Communication</b>	CAN/ RS485				
<b>Protection Mode</b>	Hardware & Software protection				
<b>Battery Protection</b>	Over-current/Over-voltage/Short circuit/ Under-voltage/Over temperature				
<b>Safety</b>	Cell UL TUV				
	CE/TUV				
<b>Hazardous Material Classification</b>	9				
<b>Transportation</b>	UN 38.3				
<b>Product Warranty</b>	10 years warranty				

Testing conditions are based on a temperature 25℃ at the beginning of life.

\*Total Energy/Usable Energy measured under specific conditions from Raystech 0.2C CC-CV.

### 3.2 Indicators and Ports

#### 3.2.1 Indicators

There are LED indicators on the front of the battery to show its operating status.

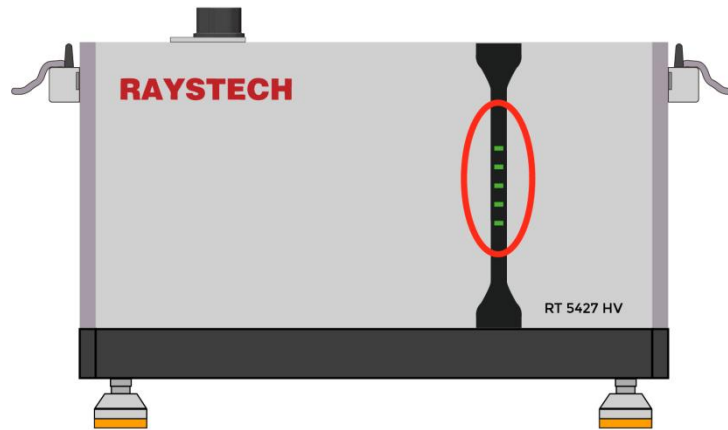

Item	Designation	Definition
1	SOC	Showing the SOC of battery

#### 3.2.2 Power and Communication Ports

This is plug and play structure between the batteries, no additional wire is required:

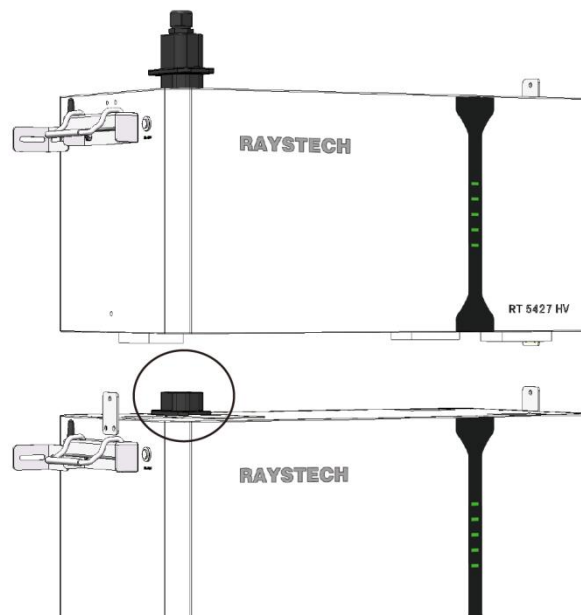

**The master battery to inverter:**

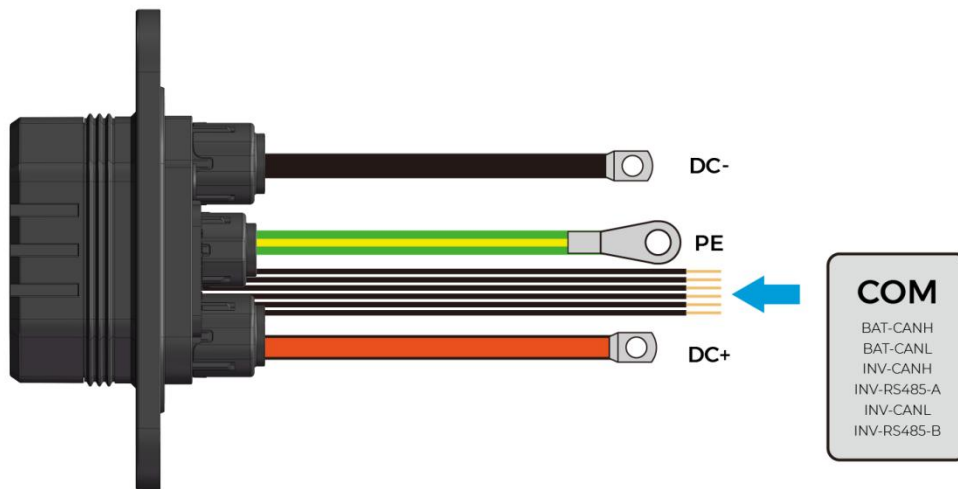

<b>CAUTION</b>	
By CAN communicating with inverter. connect INV_CANH and INV_CANL to the inverter.	
By RS485 communicating with inverter. connect INV_RS485_A and INV_RS485_B to the inverter.	
The communication cable of BAT-CANH and BAT-CANL are used for after sales team to configure program by CAN box (monitor).	

**Battery PIN definition**

Battery RJ45 CAN/RS 485		
PIN	Color	Signal Name
1	Orange&white	NA
2	Orange	NA
3	Green&white	NA
4	Blue	CAN_H
5	Blue&white	CAN_L
6	Green	NA
7	Brown&white	RS 485A
8	Brown	RS 485B

**3.3 Solution of Raystech**

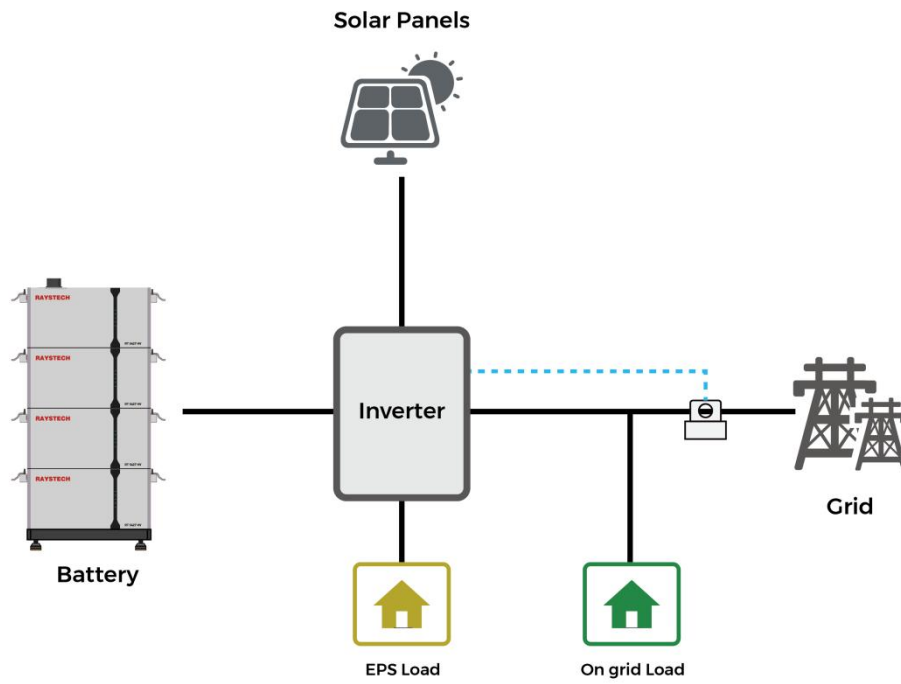

### 3.4 Feature

The Raystech Energy Storage battery has the following features:

- **Energy storage unit:** This battery is suitable for photovoltaic system compatibility.
- **Battery management system (BMS):** The built-in battery BMS monitors its operation and prevents the battery from operating outside design limitations.
- **Monitor:** The built-in battery BMS has WIFI module, and the battery operating information can be seen on mobile phones and computers.
- **Easy firmware update:** The BMS firmware can be updated to the latest version.
- **Expansibility:** The battery capacity can be increased by adding another battery.

## 4. Installation Prerequisites

### 4.1 Installation Process

The battery should be installed according to the following flow chart. The detailed installation process is described in Chapter 5 **Install process**.

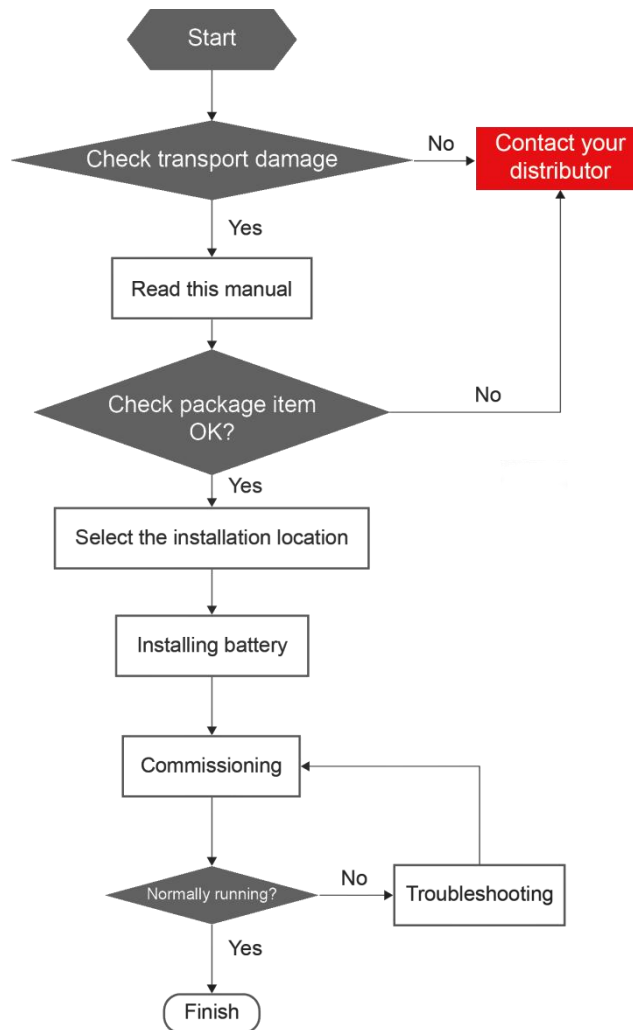

## 4.2 Installation Position





Make sure that the installation position meets the following conditions:

- The building is designed to withstand earthquakes.
- Far away from the sea to avoid salt water and humidity.
- The floor is flat and level.
- No flammable or explosive materials nearby.
- Optimal ambient temperature is between 15°C and 30°C.
- Temperature and humidity stay at a constant level.
- Minimal dust and dirt in the area.
- No corrosive gases present, including ammonia and acid vapor.
- The battery is rated at IP54, therefore the battery is suitable for indoor and outdoor with shelter usage.

If the ambient temperature is out of the operating range, the battery will protect itself by shutting down. The battery's optimal operating temperature is 15°C to 30°C. Frequent exposure to severe operating conditions will exacerbate the performance and lifetime of the battery.

## 4.3 Tools

To install the battery pack, the following tools are required:

			
<b>Phillips screwdriver</b>	<b>Torque wrench</b>	<b>Cable crimper</b>	<b>Wire clamp</b>
			
<b>Voltmeter</b>	<b>Tape measure</b>	<b>Drill</b>	<b>Flat-head screwdriver</b>

In order to protect the operator and installer's safety, please select and use suitable tools and measuring instruments that are certified for precision and accuracy.

## 4.4 Safety Instruments

When dealing with the battery, the following safety gear should be equipped. Installers must meet the relevant requirements of IEC 62040 and IEC 62619 or the domestic legislation and other relevant international standards.



## 4.5 Storage

If the battery is not to be installed immediately, and needs to be stored for a long time, please choose an appropriate location to store it. Instructions for storage are:

- Do not stack more than four battery boxes.
- The recommended storage temperature of the battery is in the range of -20°C to 30°C.
- Do not expose to water
- The battery box should be upright as shown in the following figure and shouldn't be stacked upside down when storing the battery box.

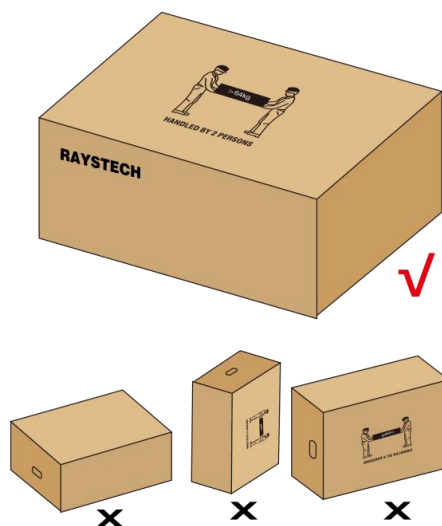

- If the battery needs to be stored over 3 months, the battery will discharge at a minimum rate and capacity will degrade depending on storage time.
- If the battery will be stored over 6 months, it is suggested to connect the battery with the inverter and commission the system.

## 5. Battery Installation

### 5.1 Checks Before Installation

There are a few things to check before installing the battery to ensure that it has no defects.

Check the battery voltage according to the following instruction:

- Press and hold the panel button for 4s and release after indicators turning on.
- Measure the voltage at the terminal interface with a voltmeter. If the voltage is lower than 96V, do not use the battery and contact customer service.

### 5.2 Battery Installation

Place the Battery in the right place. (the details about the installation position are described in Chapter 4.2).

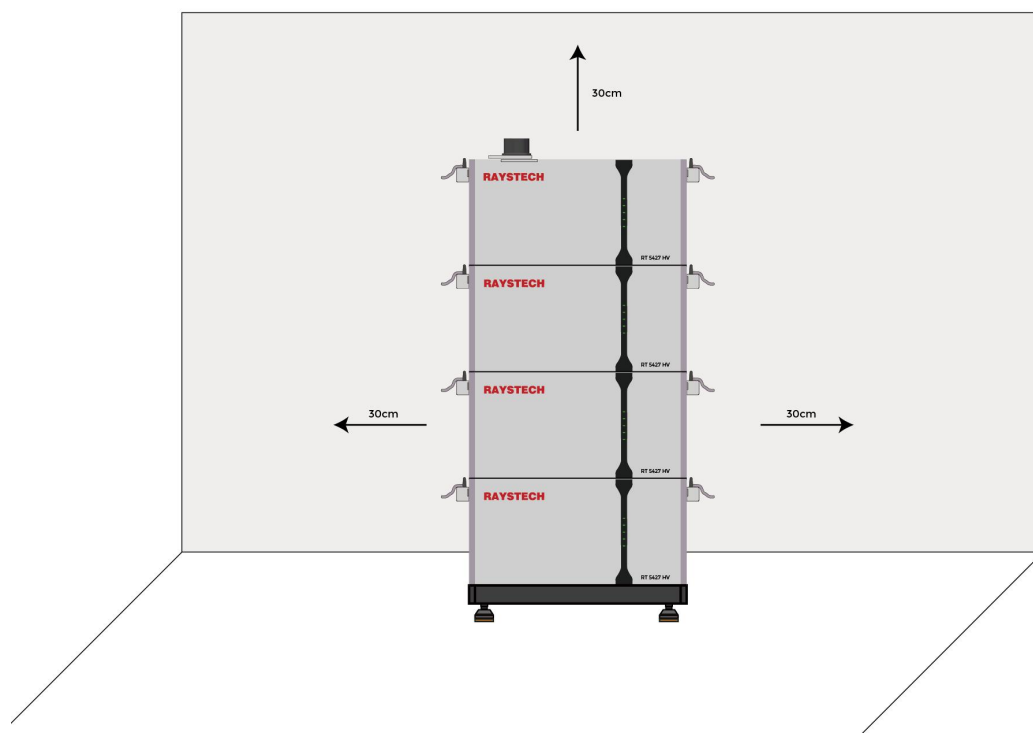

### 5.3 Connection Between Batteries

1. Turn on the Breaker: Breaker is on the top of the battery covered by a panel, open the panel . Turn on the Breaker and install the panel again.

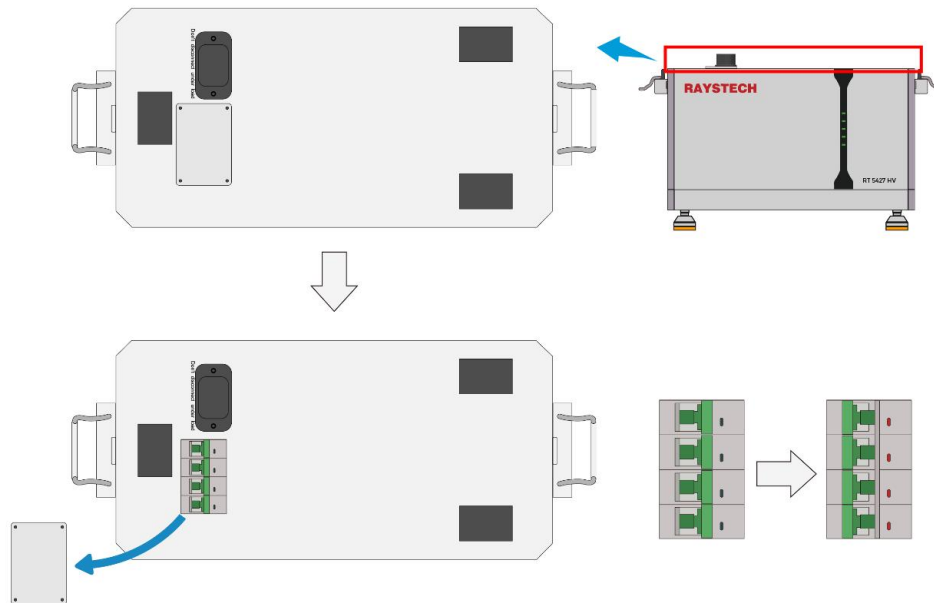

2. Install the tail plug: A tail plug should be installed to the bottom of the last battery in one cluster, So that it forms a full circuit.

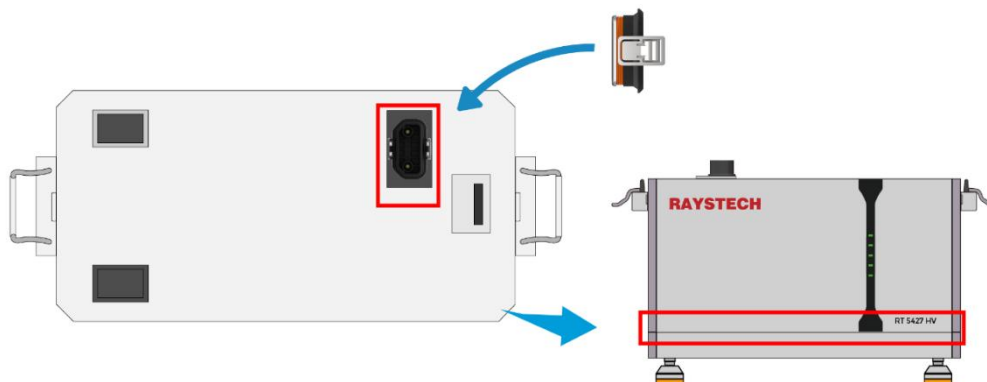

3. This product is easily mounted, just plug the upper battery into the lower one as below. Then fix the device to the wall with M6 expansion screws tightly.

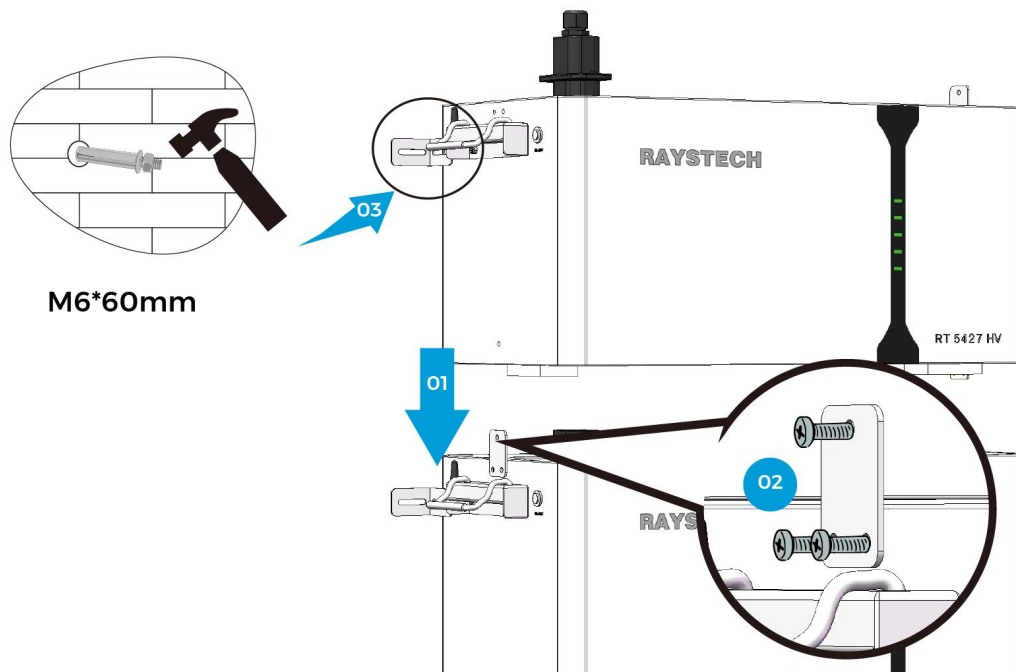

## 6. Commissioning

### 6.1 Commissioning Battery

**batteries are connected in series**, Follow the steps as below:

- 1 Check battery voltage. If the voltage is less than 96V, charge the battery first. If more assistance is needed, contact customer service.
- 2 Press the button on the upper side of the unit until the indicator lights on.
- 3 For all batteries, make sure that the Run light is on.
- 4 Make sure the maximum voltage difference between batteries is less than 2V. If not, balance the battery voltage and connect batteries in parallel together.
- 5 Turn on the inverter. Wait for the start-up sequence to complete fully.

## **6.2 Shutting Down Battery**

Shut down the battery only when the battery is no charging or discharging which can be seen in your phone with APP.

1. Press and hold the Panel Button for 5s, release after the whole lights are off.

## **7.Firmware Update**

If you need to upgrade the BMS software version, please contact the after-sales staff [service@raystechgroup.com](mailto:service@raystechgroup.com).

## RED Declaration of Conformity (DoC)

Unique identification of this DoC: .....

**We,**

RAYSTECH (TIANJIN) PV ENERGY CO., LTD  
1-1306 TOWER 1 TIANQI INTERNATIONAL MANSION, CENTRAL BUSINESS DISTRICT,  
BINHAI NEW AREA, TIANJIN, PEOPLE'S REPUBLIC OF CHINA

.....

declare under our sole responsibility that the product:

product name: RT 5427 HV

trade name:

type or model:

relevant supplementary information: .....

(e.g. lot, batch or serial number, sources and numbers of items)

**to which this declaration relates is in conformity with the essential requirements and other relevant requirements of the RED Directive (2014/53/EU).**

**The product is in conformity with the following standards and/or other normative documents:**

HEALTH & SAFETY (Art. 3(1)(a)): EN 62311:2008, EN IEC 62311:2020, EN 50663:2017

EMC (Art. 3(1)(b)): EN IEC 61000-6-1:2019, EN IEC 61000-6-3:2021, EN 301 489-1

V2.2.3:2019, EN 301 489-17 V3.2.4:2020 SPECTRUM (Art. 3(2)): EN 300 328 V2.2.2:2019

OTHER (incl. Art. 3(3) and voluntary specs): N/A

Accessories: N/A

Software: N/A

Technical file held by: RAYSTECH (TIANJIN) PV ENERGY CO., LTD

Place and date of issue (of this DoC): .....

Signed by or for the manufacturer: .....

(Signature of authorised person)

Name (in print): .....

Title: .....

# RAYSTECH

RAYSTECH (TIANJIN) PV ENERGY CO., LTD.

